

Senscient ELDS™ Series 1000 XD Cross Duct & HVAC

Fulfilling the promise of open path gas detection (OPGD)

About Senscient ELDS OPGD

ELDS™ is a patented, new open path gas detection (OPGD) technology from Senscient. The innovative Enhanced Laser Diode Spectroscopy (ELDS) detection technology featured in our ELDS Series of open path gas detectors truly fulfills the promise of fit-and-forget open path gas detection...

- **Reliable detection of both toxic & flammable gases.**
- **Industry's first false-alarm free Open Path Gas Detector.** ELDS detection is molecular species specific, eliminating false alarms from common atmospheric or non-hazardous gases that plague traditional OPGD (or any NDIR or LDS technology) systems.
- **FIRST and ONLY open path toxic gas detector to meet current industry Safety Performance Standards.**
- **FIRST and ONLY gas detector with SimuGas™, an electronic, remote functionality check.**
- **3 orders of magnitude greater sensitivity for combustible gases versus conventional OP systems.**
- **Up to 60% reduction in gas detection project Cap Ex and COO, with true Fit-&-Forget functionality.**
- **Backed by a network of industry-leading gas detection solutions providers.**



Senscient ELDS Series 1000 XD Cross Duct & HVAC Methane Detector

Features / Benefits:

- Reliable, rapid detection of methane at the lowest levels required for cross-duct and HVAC applications.
- 100% continuous measurement of the amount of gas in the duct enables rapid detection of gas without the false-alarms associated with systems that make measurement flashes just a few times a second.
- Fully heated optics and no retroreflector means no problems with condensation or hoar frost.
- No false alarms from any other hydrocarbon gases including diesel fumes or oil mist.
- True ease-of-installation, with vibration and misalignment tolerant optics.
- SimuGas™ feature provides ability to accomplish on-demand, remote functionality testing right from the control room or PLC.

Applications:

HVAC ducts, turbine inlets, turbine acoustic enclosures.

Theory of Operation:

Using a separate transmitter and receiver configuration, Senscient ELDS Series 1000 XD Cross Duct & HVAC OPGD systems can detect and measure methane in ducts between 0.5m and 5m wide. The ELDS technique measures the Harmonic Fingerprint introduced onto the transmitter's laser beam(s) by absorption by any target gas in the unit's path.



Senscient ELDS™ Series 1000 XD Cross Duct & HVAC

Fulfilling the promise of open path gas detection (OPGD)

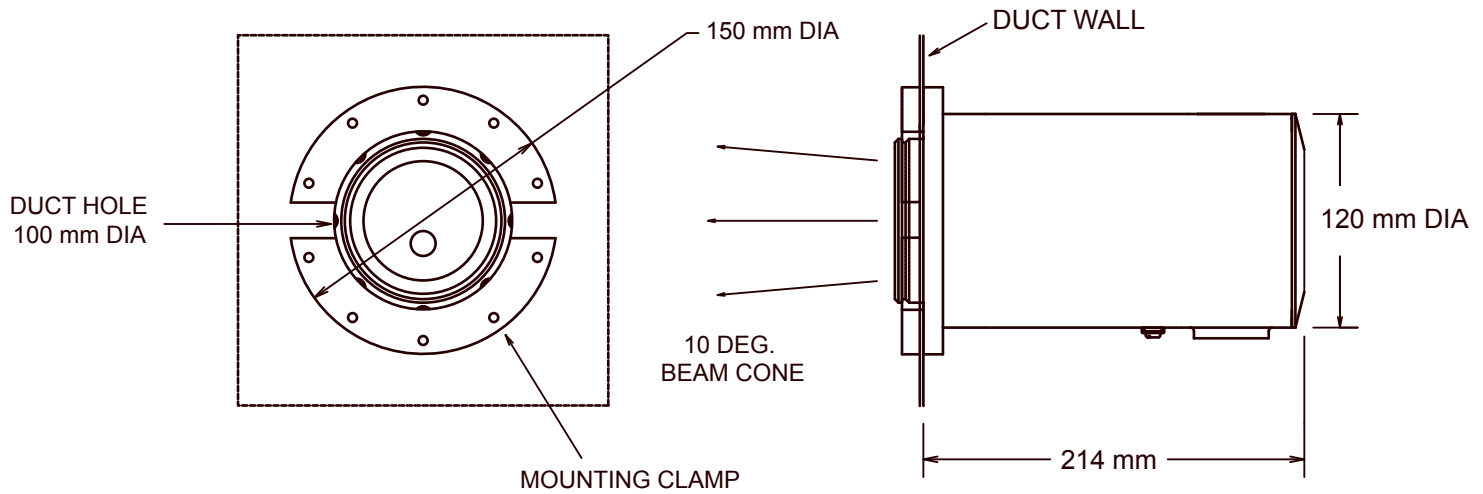

Specifications:

Gas	Methane
Ranges	0-10% LEL, 0-25% LEL, 0-100% LEL
Path-Length	0.5 - 5 m

Performance:

Response Time	T90 <= 1 second
Resolution	0.5% FSD
Repeatability	= < +/- 2% FSD
Linearity	= < +/- 2% FSD
Zero Drift	= < +/- 1% FSD
Span Drift	= < +/- 2% FSD
Min. Alarm Threshold	1% LEL (or 10% FSD, whichever is greater)

Environmental:

Ingress Protection	IP66/67, NEMA 4X/6P
Enclosure Material	316 stainless steel
Operating Temperature	-40° C to +65° C
Humidity	0 – 100% RH (non-condensing)
Vibration	10 – 150 Hz, 2 g
EMC	EN50270

Certification / Approvals:

Designed to comply with US and Canadian standards*:
 Class 1 Div 1 Groups B C & D, (IIB + H2) T5 Tamb = -40° C to +65° C
 Class 1 Zone 1 AExd/Exd (IIB + H2) T5 Tamb = -40° C to +65° C
 Supply Entry ¾" NPT - 14 TPI

Designed to comply with ATEX (Europe) standards*:
 II 2 G, Exd (IIB + H2) T5 Tamb = -40° C to +65° C
 Supply Entry M25

* Pending performance approval

Electrical:

Operating Voltage	+24 V nominal, operates correctly for supply voltages between +12 V and +32 V
Power Consumption	TX = 10 W (max), RX = 7.5 W (max)
Output (Analogue)	4-20 mA (2 wire, isolated) Configurable for single wire, sink or source Capable of driving 0-600 Ohm load
Low Signal	3 mA (configurable 1 mA to 4 mA)
Beam Block	2.5 mA (configurable 0 mA to 3.5 mA)
Inhibit	2 mA (configurable 1 mA to 4 mA)
Fault	0 mA
Output (Digital)	RS485 (Isolated), MODBUS protocol

Mechanical:

Size	TX/RX 140 mm dia. x 300 mm
Weight	TX/RX 9 kg
Mounting	TX & RX units supplied with mounting flanges and clamp plates suitable for mounting units on flat duct walls.

Optical:

The unit will operate correctly, without spurious readings or faults during conditions of misalignment or partial obscuration.

Alignment	+/- 5°
Obscuration	90%
Heated Optics	The window-lenses of the TX and RX units are heated.

Calibration, Testing & Maintenance:

Calibration	Units supplied factory calibrated for the specified target gas or gases. Units should not require re-calibration in service.
-------------	--

Part Numbers:

Senscient ELDS V-GGGG-C

Where:-

V	= XD =	Standard
GGGG	= 1020 =	0-10% LEL Methane
	= 1021 =	0-25% LEL Methane
	= 1022 =	0-100% LEL Methane
C	= 1 =	FM/CSA
	= 2 =	ATEX

E.g. Senscient ELDS XD-1020-1 is a Cross-Duct Senscient ELDS calibrated for 0-10% LEL Methane with FM & CSA approval.

Distributed by: